

## BEFORE YOU BEGIN

Read these instructions and check to be sure all parts and tools are accounted for. Please retain these installation instructions for future reference.

## IMPORTANT

This Inner Fairing Trim Kit is exclusively designed for your vehicle. Please read the installation instructions thoroughly before beginning. Installation is easier if the vehicle is clean and free of debris.

Warning: Shift vehicle transmission into "PARK". Turn key to "OFF" position and remove from vehicle. To prevent accidental vehicle start-up, which could cause death or serious injury, remove main fuse before proceeding. See the owner's manual to remove the main fuse.

## INSTALLATION INSTRUCTIONS

1. Clean the entire mounting surface.
2. Remove the film of the tape on the back of the products, stick the products to the corresponding instrument panels, and press them hard to make them stick firmly.

### Installation finished

**Note:** If the trim DOES NOT slip easily behind the ignition switch knob, remove the ignition switch knob before installing the radio trim. To remove the ignition switch knob:

- a. Insert the ignition switch key and turn to the UNLOCK position. Leave the key installed.
- b. See Figure 1. Rotate knob to FORK LOCK.
- c. Press and hold the release button at the bottom left side of the knob. Turn the key 60 degrees counterclockwise.
- d. Lift knob to remove. A spring drops out of the bore on the underside when removed. Retain for reassembly.
- e. DO NOT rotate the switch to other positions while knob is removed.

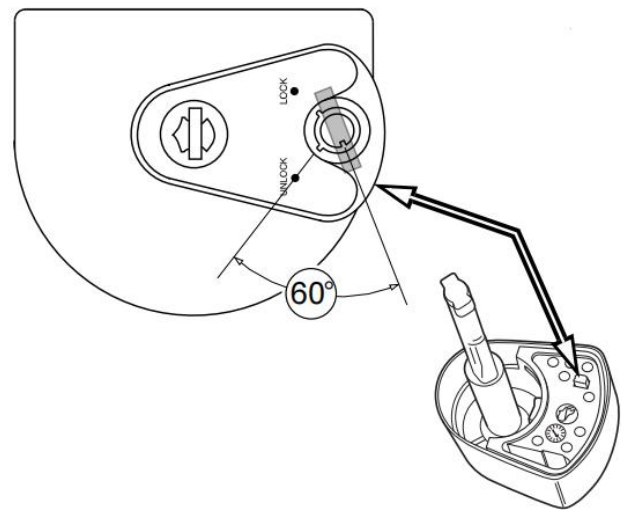

**Figure 1. Ignition Switch Knob Release Button (Top and Bottom Views)**